

Swing Door Automation

ACSW30 (EN16005:2002 compliant)

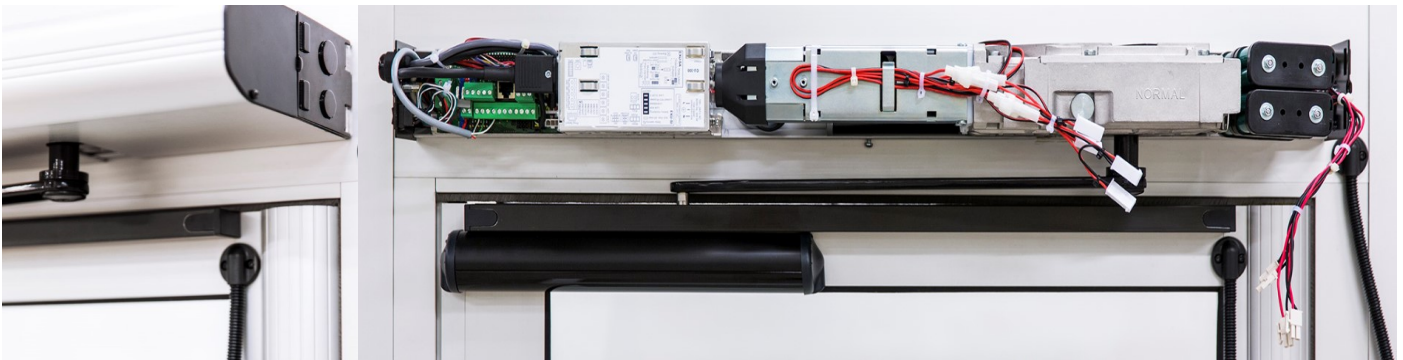

The ACSW30 is one of the most powerful, safe and flexible door operators in the market. The super slim electromechanical operator is designed for silent operation and maximum reliability.

Powerful Operation

Offering silent operation and high performance, the ACSW30 can operate heavy doors up to 250Kg with ease, and ensures a proper operation in a wide range of air pressure differences or tough weather conditions (e.g. heavy wind loads).

Intelligent Controls

The use of clever features such as “Push and Go” and “Power Assist” allows the ACSW30 to be easily manually opened. The optional low energy setting limits the speed and force during opening and closing. Equally, the ACSW30 can be fitted with monitored safety sensors and thereby ensure a safe entrance during Full-Energy

operation. When the safety sensors detect an obstacle during opening phase, the door stops. When an obstacle is detected during closing phase, it stops and reverses the direction. If a monitored sensor detects an error, the door is automatically stopped and changes into manual operation.

Wide Ranging Applications

The ACSW30 is approved for use on fire doors, both with single doors and double doors (thanks to its unique mechanical coordination unit). The ACSW30 is the ideal choice for almost any application, e.g. in Cleanroom, Healthcare, Laboratory, Food Preparation and Controlled environments. And the intelligent self-learning cycle is a guarantee for quick and correct commissioning of the operator, meaning the ACSW30 requires minimal maintenance.

Call us:

1890 274 273

Visit us:

**Unit C Purcellsinch Industrial Estate,
Old Dublin Road, Kilkenny, R95 EH52**

Email / Website:

**admin@actec.ie
www.actec.ie**

Swing / Sliding Automations

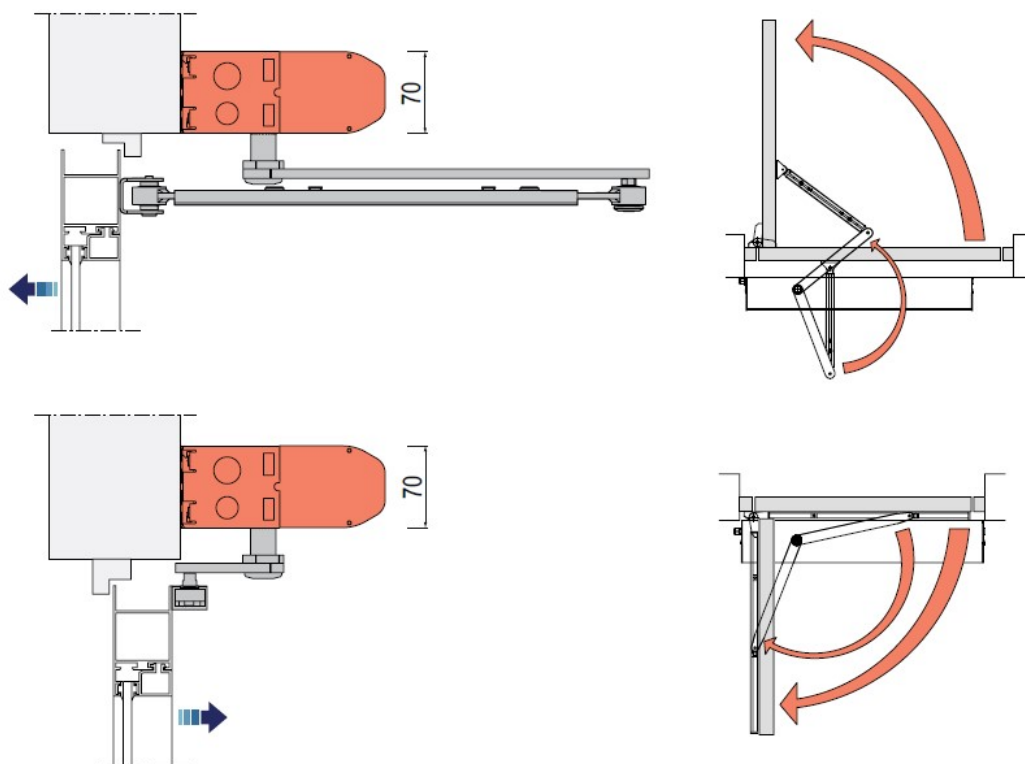

Technical Specifications:

Power Supply:	100-240Vac, +10/-15%, 50/60Hz
Power Consumption:	Max 300W
Auxiliary Voltage:	24Vdc (Max 700mA)
Maximum Door Weight:	250Kg
Lock Output:	12Vdc 1200mA 24Vdc 600mA
Reveal (Push):	0—22mm standard (Up to 367mm with extensions)
Reveal (Pull):	0—114mm
Door Opening Angle:	80° - 110° (adjustable)
Opening Time:	2.5—12 seconds (adjustable)
Closing Time:	4—12 seconds (adjustable)
Ambient Temperature:	-20° to + 45° C
IP Rating:	IP20 (with standard canopy)

Humidity Rating:	85% non condensing
Hold Open Time:	1.5—30 seconds
Motor Weight:	7.6 Kg
Dimensions:	Height - 70mm Depth - 175mm Length - 840mm



Accessories

- Backup Battery Pack
- Security and Impulse Expansion Card
- Safety Expansion Card
- Off / Auto / Hold Open Switch
- Mechanical Coordinator Kit for fire door coordination with or without power
- LED Indicator
- Stainless Steel Canopy (Double or Single Width)

Contact us for more information